

ÖCEANUS

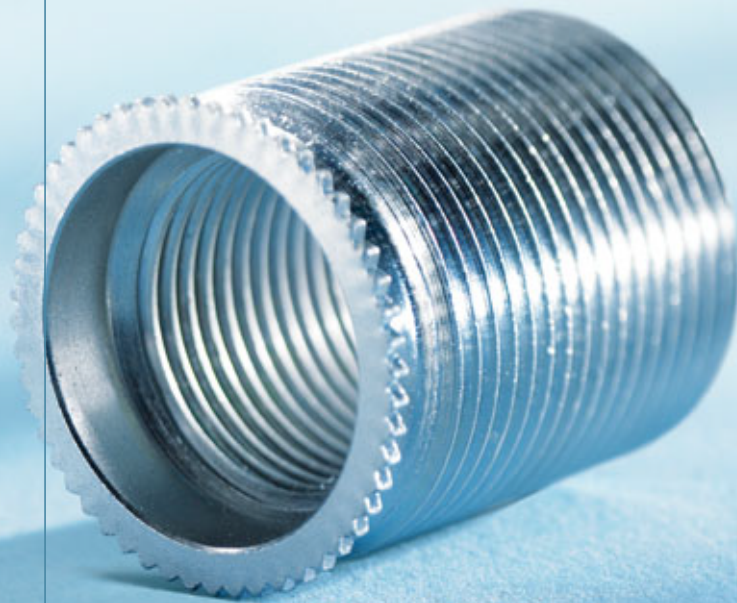

KOBSERT ®

Thread inserts for metals

BÖLLHOFF

Contents

KOBSERT® <i>Thread inserts for metals</i>	Page
The principle	3
The benefits	3
Product types	3
Applications in the Automotive and General industry	4
Technical information	5
Guidelines for KOBSERT®	10
Manual setting tools	12
Mechanical setting tools	14

KOBSERT® *Thread inserts for metals*

The principle

When installing the threaded inserts, the safety flange is pressed into the surface of the parent material. (This reduces the pipe-shaped neck area under the safety flange and covers as far as the mounting thread).

After installation into the part, the threaded inserts are reliably protected against unscrewing, even when the part is exposed to dynamic screwload or extreme temperatures. Due to the installation process where the KOBSERT® body is pulled into the same direction like the screwload, the clearance of the external thread is compensated. The external thread is pre-setted properly.

If, in exceptional cases, it is necessary to remove the threaded insert, follow the instructions on page 10.

KOBSERT® *Thread insert*

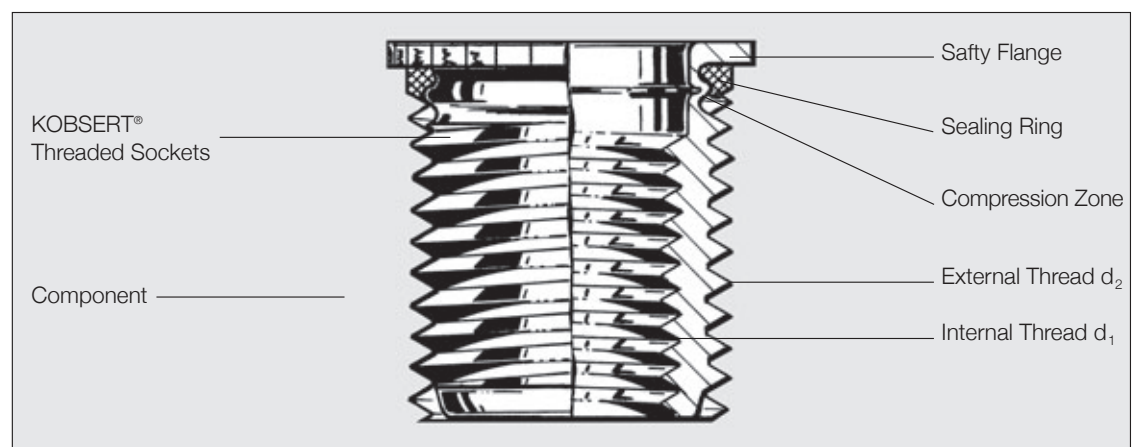

The benefits

KOBSERT® thread inserts achieve a heavy-duty connection capability in low-strength metal materials for instance in aluminium and magnesium alloys.

- Creation of high-strength, wear-resistant, vibration-resistant and torsion-proof nut threads.
- Tight fit: The KOBSERT® is mechanically anchored without additional securing pins or washers and without chemical adhesion or sealing materials.
- Thread repair: KOBSERT® thread inserts also serve to repair damaged threads.
- Sealing function: The KOBSERT® thread insert with sealing ring is designed for gas- and liquid-tight joints.

Design

Metric ISO thread DIN 13, tolerance range for industry standard screws and nuts tolerance 6g/6H.

Surface

- DIN 267 Part 2 Product Class A.

Material

- Steel, galvanic Zink plated, colourless chromated (for Order no. see page 5 – 9).
- Stainless steel, coatless (5th digit of the order no. changes from 0 to 6).

Sealing Ring

- PERBUNAN® (eWZ Bayer AG) 70 Shore A, heat resistant to ~140°C.
[VITON®, eWZ E.I. Dupont de Nemours & Co. INC.], to 300°C (put 1 as the 5th digit of the order no.).

Other specifications available on request.

KOBSERT [®] *Applications*

Automotive

- Engine attachments
- Gear box connection
- Towing lugs

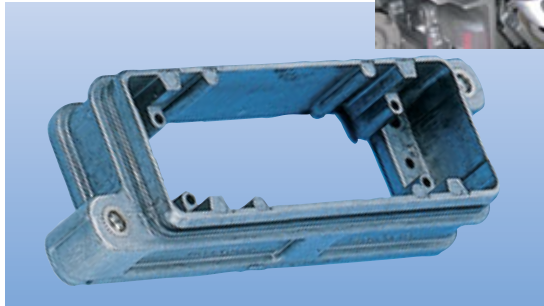

General industry

- Refrigeration and air conditioning technology
- Electrical engineering/electronics, e.g. switchboards, connectors
- Agricultural technology
- Garden technology



KOBSERT® Threaded inserts

Type 1030

- Safety flange
- Open version/through hole

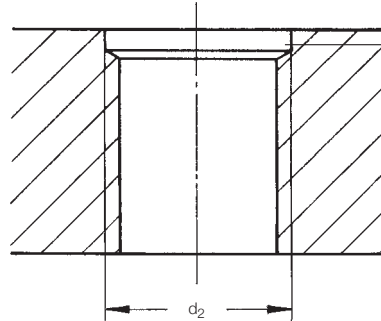
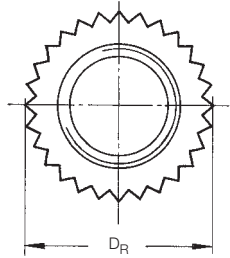
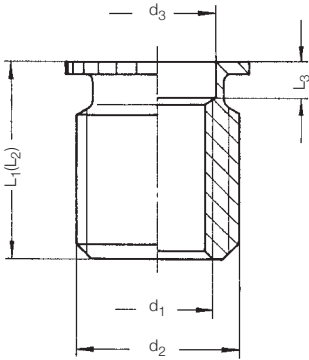

Countersinking cylindrical portion is only necessary for aluminium alloys with high tensile strength (ca. 250 N/mm², see page 6).

Material: Steel, galvanic zink plated, colourless chromated

Installation tools see pages 12 – 15

d ₁	Order no.	d ₂	d ₃	L ₁ [*]	L ₂ [*]	L ₃ [*]	D _R	Knurl DIN 82
M 4 ^{***}	1030 0040 008	M 7	4.35	8	8.6	3.3	7.6	1.2
M 5	1030 0050 010	M 8	5.35	10	10.8	3.5	8.8	1.2
M 6	1030 006 0010	M 10	6.8	10	11	2.7	11	1.2
M 6	1030 006 0012	M 10	6.8	12	13	2.7	11	1.2
M 8	1030 008 0015	M 12 x 1.5 ^{**}	8.5	15	16	3.3	13	1.6
M 10	1030 010 0018	M 14 x 1.5	10.5	18	19	3.3	15	1.6
M 12 x 1.5	1030 012 4021	M 16 x 1.5	12.5	21	22	3.5	17	1.6
M 12	1030 012 0021	M 16 x 1.5	12.5	21	22	3.5	17	1.6
M 14 x 1.5	1030 014 4024	M 20 x 1.5	15.5	24	25	3.6	21	1.6
M 14	1030 014 0024	M 20 x 1.5	15.5	24	25	3.6	21	1.6
M 16 x 1.5	1030 016 4026	M 22 x 1.5	17.5	26	27	3.6	23	1.6
M 16	1030 016 0026	M 22 x 1.5	17.5	26	27	3.6	23	1.6

Material: Stainless steel A1

Installation tools see pages 12 – 15

d ₁	Order no.	d ₂	d ₃	L ₁ [*]	L ₂ [*]	L ₃ [*]	D _R	Knurl DIN 82
M 4	1030 6040 008	M 7	4.35	8	8.6	3.3	7.6	1.2
M 5	1030 6050 010	M 8	5.35	10	10.8	3.5	8.8	1.2
M 6	1030 6060 012	M 10	6.8	12	12.8	3.5	10.8	1.2
M 8	1030 6080 015	M 12 x 1.5	8.5	15	16	4.5	12.9	1.6
M 10	1030 6100 018	M 14 x 1.5	10.7	18	19	4.6	15	1.6
M 12	1030 6120 021	M 16 x 1.5	12.5	21	22	4.5	17	1.6
M 12 x 1.5	1030 6124 021	M 16 x 1.5	12.5	21	22	4.5	17	1.6
M 14	1030 6140 024	M 20 x 1.5	15.5	24	25	4.8	21	1.6
M 16	1030 6160 026	M 22 x 1.5	17.5	26	27	4.8	23	1.6

* L₁, L₃ = Length when assembled. * L₂ = Length in delivery conditions. Other lengths available on request.

** also available with pitch 1.25

*** on request

Different materials on request. Further technical details on page 3. Subject to technical alterations.

KOBSERT® *Threaded inserts*

Type 1031

- Safety flange
- Open version/through hole
- With sealing ring: PERBUNAN®

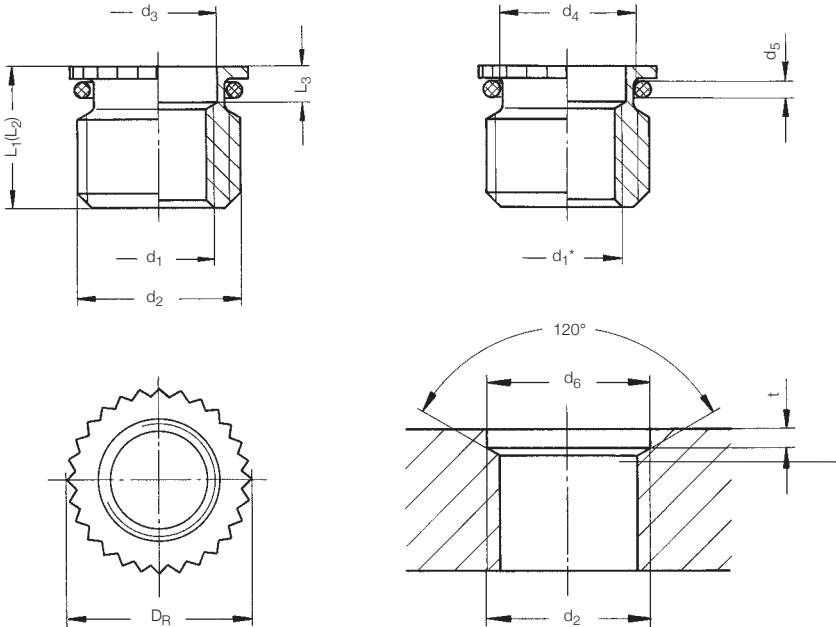

Sealing ring:
 PERBUNAN® as standard, 70 Sh A
 Heat resistance ~ + 140 °C
 Colour coding: black

Alternative: VITON® 75 Sh A
 Heat resistance: max. + 300 °C
 Colour coding: green

Material: Steel, galvanic zink plated, colourless chromated

Installation tools see pages 12 – 15

d ₁	Order no.	d ₂	d ₃	L ₁ *	L ₂ *	L ₃ *	D _R	Knurl DIN 82	Sealing ring d ₄ x d ₅	d ₆	Countersink		
											Tol.	t	+ Tol.
M 10 x 1 [®]	1031 010 3010	M 14 x 1.5	10.5	10	11	3.2	15	1.6	10 x 1.5	14	± 0.10	2.5	0.3
M 12 x 1.5	1031 012 4012	M 16 x 1.5	12.5	12	13	3.5	17	1.6	12 x 1.5	16	± 0.10	2.5	0.3
M 14 x 1.5	1031 014 4012	M 20 x 1.5	15.5	12	13	3.6	21	1.6	14 x 2.0	20	+0.15/-0.10	3.0	0.3
M 16 x 1.5	1031 016 4012	M 22 x 1.5	17.5	12	13	3.6	23	1.6	16 x 2.0	22	+0.15/-0.10	3.0	0.3
M 18 x 1.5	1031 018 4012	M 24 x 1.5	19.5	12	13	3.6	25	1.6	18 x 2.0	24	+0.15/-0.10	3.0	0.3
M 20 x 1.5	1031 020 4014	M 26 x 1.5	21.5	14	15	3.6	27	1.6	20 x 2.0	26	+0.15/-0.10	3.0	0.3
M 22 x 1.5	1031 022 4014	M 28 x 1.5	23.5	14	15	3.6	29	1.6	22 x 2.0	28	+0.15/-0.10	3.0	0.3
M 24 x 1.5	1031 024 4014	M 30 x 1.5	25.5	14	15	3.6	31	1.6	24 x 2.0	30	+0.15/-0.10	3.0	0.3
M 26 x 1.5	1031 026 4016	M 32 x 1.5	27.5	16	17	3.6	33	1.6	26 x 2.0	32	+0.15/-0.10	3.0	0.3

* L₁, L₃ = Length when assembled. * L₂ = Length in delivery conditions. Other lengths available on request.

① Type 1031 is preferable for short screw lengths DIN 908 and 910.

Different materials on request. Further technical details on page 3. Subject to technical alterations.

KOBSERT® *Threaded inserts*

Type 1032

- Safety flange with sealing flange
- Open version/through hole
- With sealing ring: PERBUNAN®

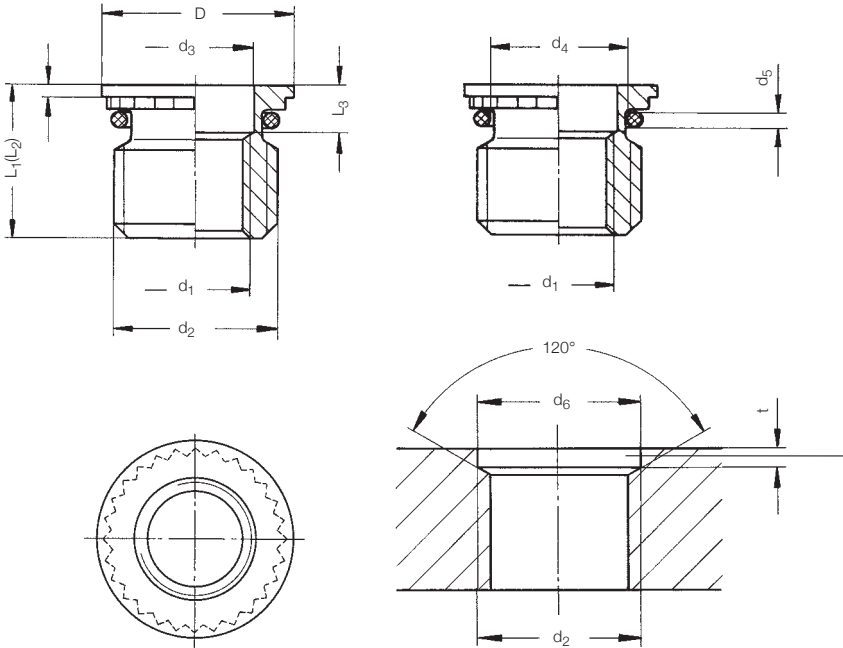

Sealing ring:
 PERBUNAN® as standard, 70 Sh A
 Heat resistance ~ + 140 °C
 Colour coding: black

Alternative: VITON® 75 Sh A
 Heat resistance: max. + 300 °C
 Colour coding: green

Material: Steel, galvanic zink plated, colourless chromated

Installation tools see pages 12 – 15

d ₁	Order no.	d ₂	d ₃	D	L ₁ *	L ₂ *	L ₃ *	L ₅	D _R	Knurl DIN 82	Sealing ring d ₄ x d ₅	d ₆	Countersink Tol. t + Tol.		
M 10 x 1	1032 010 3011	M 14 x 1.5	10.5	16	11.0	12.0	4.0	0.8	15	1.6	10 x 1.5	14	± 0.10	2.5	0.3
M 12 x 1.5	1032 012 4145	M 16 x 1.5	12.5	18	14.5	15.5	4.4	0.8	17	1.6	12 x 1.5	16	± 0.10	2.5	0.3
M 14 x 1.5	1032 014 4145	M 20 x 1.5	15.5	22	14.5	15.5	4.5	1.0	21	1.6	14 x 2.0	20	+0.15/-0.10	3.0	0.3
M 16 x 1.5	1032 016 4145	M 22 x 1.5	17.5	24	14.5	15.5	4.5	1.0	23	1.6	16 x 2.0	22	+0.15/-0.10	3.0	0.3
M 18 x 1.5	1032 018 4145	M 24 x 1.5	19.5	26	14.5	15.5	4.7	1.2	25	1.6	18 x 2.0	24	+0.15/-0.10	3.0	0.3
M 20 x 1.5	1032 020 4155	M 26 x 1.5	21.5	28	15.5	16.5	4.7	1.2	27	1.6	20 x 2.0	26	+0.15/-0.10	3.0	0.3
M 22 x 1.5	1032 022 4155	M 28 x 1.5	23.5	30	15.5	16.5	4.7	1.2	29	1.6	22 x 2.0	28	+0.15/-0.10	3.0	0.3
M 24 x 1.5	1032 024 4155	M 30 x 1.5	25.5	32	15.5	16.5	4.7	1.2	31	1.6	24 x 2.0	30	+0.15/-0.10	3.0	0.3
M 26 x 1.5	1032 026 4175	M 32 x 1.5	27.5	34	17.5	18.5	4.7	1.2	33	1.6	26 x 2.0	32	+0.15/-0.10	3.0	0.3
M 30 x 1.5	1032 030 4175	M 36 x 1.5	31.5	38	17.5	18.5	4.7	1.2	37	1.6	30 x 2.0	36	+0.15/-0.10	3.0	0.3

Material: Stainless steel A1

Installation tools see pages 12 – 15

d ₁	Order no.	d ₂	d ₃	D	L ₁ *	L ₂ *	L ₃ *	L ₅	D _R	Knurl DIN 82	Sealing ring d ₄ x d ₅	d ₆	Countersink Tol. t + Tol.		
M 12 x 1.5	1032 6124 145	M 16 x 1.5	12.5	18	14.5	15.5	4.8	0.8	18	1.6	12 x 1.5	16	± 0.10	2.5	0.3
M 14 x 1.5	1032 6144 145	M 20 x 1.5	15.5	22	14.5	15.5	5.5	0.8	22	1.6	14 x 2.0	20	+0.15/-0.10	3	0.3

* L₁, L₃ = Length when assembled. * L₂ = Length in delivery conditions. Other lengths available on request.
 Different materials on request. Further technical details on page 3. Subject to technical alterations.

KOBSERT® Threaded inserts

Type 1033

- Safety flange
- Closed version/blind hole
- With sealing ring: PERBUNAN®

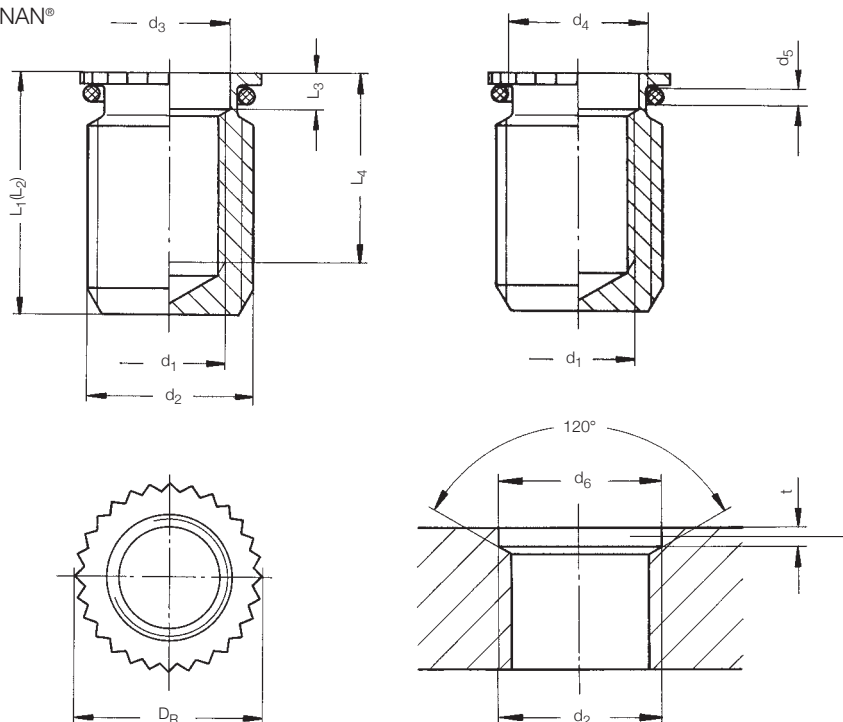

Sealing ring:
 PERBUNAN® as standard,
 70 Sh A
 Heat resistance ~ + 140 °C
 Colour coding: black

Alternative: VITON® 75 Sh A
 Heat resistance:
 max. + 300 °C
 Colour coding: green

Material: Steel, galvanic zink plated, colourless chromated

Installation tools see pages 12 – 15

d ₁ *	Order no.	d ₂	d ₃	L ₁ **	L ₂ **	L ₃ **	L ₄ **	D _R	Knurl DIN 82	Sealing ring d ₄ x d ₅	d ₆	Countersink Tol.	t	+ Tol.
M 5	1033 005 0012	M 8	5.4	12	13	2.7	8.0	9	1.2	5 x 1.0	8	± 0.10	2.0	0.3
M 6	1033 006 0015	M 10	6.8	15	16	2.7	10.5	11	1.2	6 x 1.5	10	± 0.10	2.5	0.3
M 8	1033 008 0018	M 12 x 1.5	8.5	18	19	3.3	12.0	13	1.6	8 x 1.5	12	± 0.10	2.5	0.3
M 10	1033 010 0021	M 14 x 1.5	10.5	21	22	3.3	13.9	15	1.6	10 x 1.5	14	± 0.10	2.5	0.3
M 12	1033 012 0024	M 16 x 1.5	12.5	24	25	3.5	15.9	17	1.6	12 x 1.5	16	± 0.10	2.5	0.3
M 14	1033 014 0026	M 20 x 1.5	15.5	26	27	3.6	16.9	21	1.6	14 x 2.0	20	+0.15/-0.10	3.0	0.3
M 16	1033 016 0031	M 22 x 1.5	17.5	31	32	3.6	20.9	23	1.6	16 x 2.0	22	+0.15/-0.10	3.0	0.3

Material: Stainless steel A1

Installation tools see pages 12 – 15

d ₁ *	Order no.	d ₂	d ₃	L ₁ **	L ₂ **	L ₃ **	L ₄ **	D _R	Knurl DIN 82	Sealing ring d ₄ x d ₅	d ₆	Countersink Tol.	t	+ Tol.
M 4	1033 6040 012	M 7	4.35	12	13	3.3	8.2	7.6	1.2	4 x 1.0	7	± 0.10	1.8	0.3
M 5	1033 6050 012	M 8	5.35	12	13	3.5	8	8.8	1.2	5 x 1.0	8	± 0.10	2	0.3
M 6	1033 6060 015	M 10	6.8	15	16	3.5	10.5	10.8	1.2	6 x 1.5	10	± 0.10	2.5	0.3
M 8	1033 6080 018	M 12 x 1.5	8.5	18	19	4.5	12	12.9	1.6	8 x 1.5	12	± 0.10	2.5	0.3
M 10	1033 6100 021	M 14 x 1.5	10.7	21	22	4.6	13.9	15	1.6	10 x 1.5	14	± 0.10	2.5	0.3

* Available with fine thread.

** L₁, L₃, L₄ = Length when assembled. ** L₂ = Length in delivery conditions. Other lengths available on request.

Different materials on request. Further technical details on page 3. Subject to technical alterations.

KOBSERT® *Threaded inserts*

Type 1040

- HP – High Power
- Safety flange
- Open version/through hole
- With or without sealing ring:
PERBUNAN®

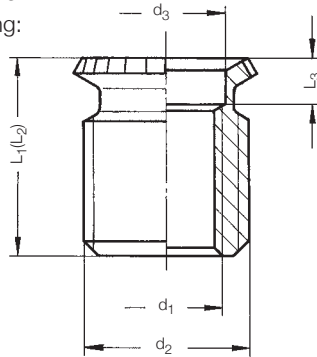

Typ 1041 with sealing ring*

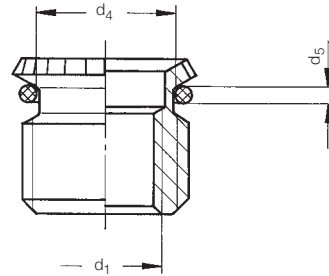

Sealing ring:
PERBUNAN® as standard,
70 Sh A
Heat resistance ~ + 140 °C
Colour coding: black

Alternative: VITON® 75 Sh A
Heat resistance:
max. + 300 °C
Colour coding: green

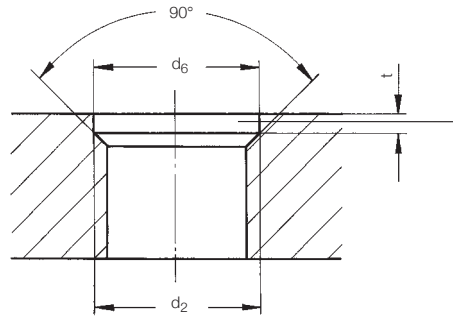
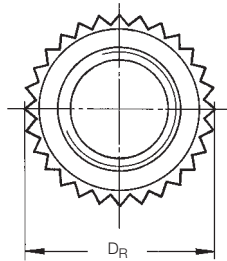

Material: Steel, galvanic zink plated, colourless chromated

Installation tools see pages 12 – 15

d ₁ *	Order no.	d ₂	d ₃	L ₁ **	L ₂ **	L ₃ **	D _R	Knurl DIN 82	Sealing ring d ₄ x d ₅	d ₆	Countersink Tol. t + Tol.		
M 5	1040 005 0010	M 10	5.5	10	11.0	1.5	11	1.2	7 x 1.5	10	± 0.1	2.5	0.3
M 6	1040 006 0012	M 12 x 1.5	6.5	12	13.5	1.6	13	1.2	8 x 2.0	12	± 0.1	3.0	0.3
M 8	1040 008 0015	M 14 x 1.5	8.5	15	16.5	1.8	15	1.6	10 x 2.0	14	± 0.1	3.5	0.3
M 10	1040 010 0018	M 16 x 1.5	10.5	18	20.0	2.0	17	1.6	12 x 2.0	16	± 0.1	4.0	0.3
M 12	1040 012 0021	M 20 x 1.5	13.0	21	23.0	2.5	21	1.6	15 x 2.5	20	+ 0.15/- 0.10	4.5	0.4
M 14	1040 014 0024	M 22 x 1.5	15.0	24	26.0	2.5	23	1.6	17 x 2.5	22	+ 0.15/- 0.10	4.5	0.4
M 16	1040 016 0026	M 24 x 2.0	17.0	26	28.0	3.0	25	1.6	19 x 2.5	24	+ 0.18/- 0.10	4.5	0.4

Material: Stainless steel A1

Installation tools see pages 12 – 15

d ₁ *	Order no.	d ₂	d ₃	L ₁ **	L ₂ **	L ₃ **	D _R	Knurl DIN 82	Sealing ring d ₄ x d ₅	d ₆	Countersink Tol. t + Tol.		
M 6***	1040 6060 012	M 12 x 1.5	6.5	12	13.5	4	13	1.2	8 x 2	12	± 0.1	3	0.3
M 8***	1040 6080 015	M 14 x 1.5	8.5	15	16.5	4.2	15	1.6	10 x 2	14	± 0.1	3.5	0.3
M 10	1040 6100 018	M 16 x 1.5	10.5	18	20	4.2	17	1.6	12 x 2	16	± 0.1	4	0.3
M 12	1040 6120 021	M 20 x 1.5	13	21	23	5	21.2	1.6	15 x 2.5	20	+ 0.15/- 0.10	4.5	0.3
M 14***	1040 6140 024	M 22 x 1.5	15	24	26	5	23	1.6	17 x 2.5	22	+ 0.15/- 0.10	4.5	0.3
M 16	1040 6160 026	M 24 x 2	17	26	28	5.5	25.2	1.6	19 x 2.5	24	+ 0.15/- 0.10	4.5	0.3
M 16 x 1	1040 6163 026	M 24 x 2	17	26	28	5.5	25.2	1.6	19 x 2.5	24	+ 0.18/- 0.10	4.5	0.3

* Other diameters and threads on request. When ordering type 1041 (with sealing ring) the 4th digit of the order no. changes from 0 to 1.

** L₁, L₃ = Length when assembled. ** L₂ = Length in delivery conditions. Other lengths available on request. *** on request

Different materials on request. Further technical details on page 3. Subject to technical alterations.

Mounting thread

Metric ISO threads according to DIN 13, tolerance 6 H.

The mounting thread should be checked with a thread gauge tolerance 6 H.

Thread hole

The minor diameter of the thread hole has to be drilled according to DIN 13 tolerance 6 H.

In general, the tapped hole should not be countersunk. Chamfering is permissible, within the diameter, but should not be greater than the specified diameter of the mounting thread.

If the KOBSSERT® or the KOBSSERT® HP is used with a sealing ring, a cylindrical portion in accordance with pages 3 to 7 should be created.

Installation

Manual and motor-driven tools are available for installing the KOBSSERT®. The KOBSSERT® insert is screwed into the part until the safety flange is in contact to the surface of the part. The installation procedure – pressing the safety flange into the part – is carried out by a relative axial movement between the spindle, which has been screwed in, and the frontend assembly of the installation tool. After the setting process the spindle has to be turned out of the KOBSSERT®.

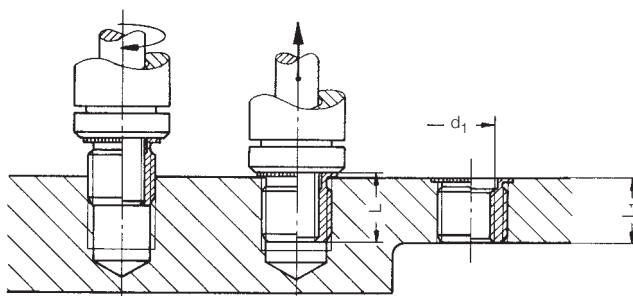
**Disassembly**

If KOBSSERT® threaded inserts must be removed from a part, it must be done as follows (see sketch):

- Drilling into the safety flange until reaching the external thread (Drill \varnothing = external thread $\varnothing d_2$).
- Lever out the safety flange using a scraper or a screwdriver.
- Insert a tool for unscrewing – if necessary a suitable scraper – into the internal thread, so it is possible to turn it. Unscrew the socket anticlockwise.

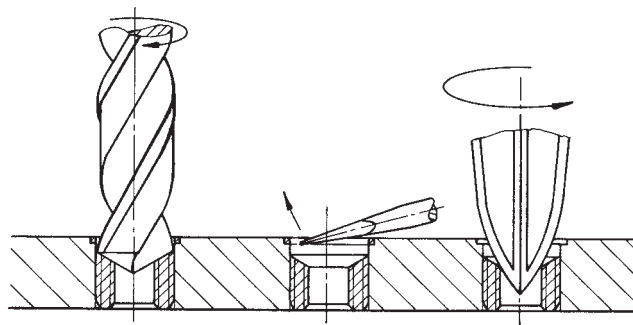
**New installation**

Screw in a threaded insert of the same specified size, until the safety flange is level with the previous impression – if necessary, unscrew it a little – and as usual, set it on one level with the surface using an KOBSSERT® installation tool.

**Wall thickness specifications for aluminium materials
(casted and forging alloys)**

The minimum width S or the wall thickness S_R depends on the tenside strength and the E-Modul of the parent material. The following formula only gives guide values for aluminium alloys. For other materials, e. g. copper or brittle materials, the required wall thickness should be established by performing tests. Dimensions of the mounting thread see page 5 to 9.

$S = 1.4 \times D_R$	$S_R = 0.2 \times D_R$
----------------------	------------------------

S = Minimum width of workpice
 S_R = Minimum wall thickness
 D_R = Outer diameter of safety flange
 (knurl diameter)

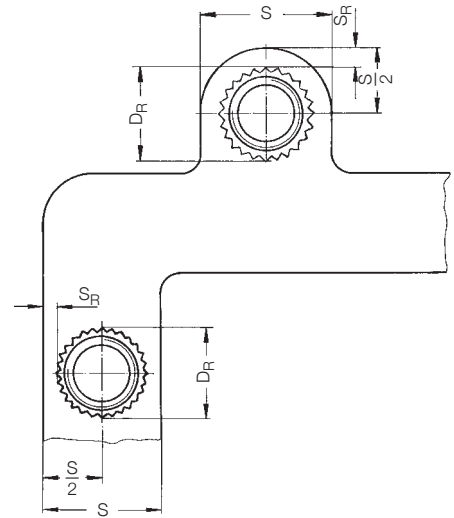

Pull out load in relation to screw class on tensile strength of parent material

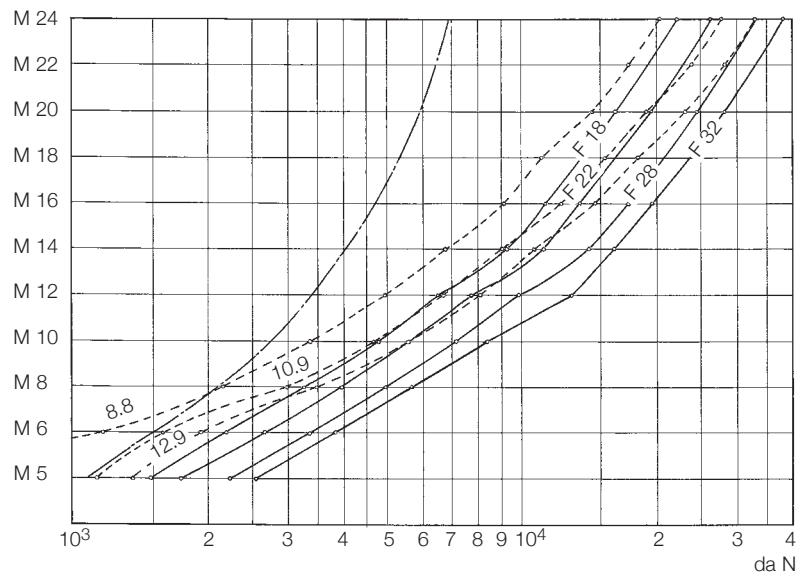

- Pull out load for type 1030 and 1033 KOBSERT® threaded inserts in standard lengths, in different material qualities, including: F 18, F 22, F 26, F 32. Tear strengths are 30 to 50 % higher. Test strengths type 1040/1041 on request.
- Test strengths of screws of different strength classes (8.8–10.9–12.9) ~ 90% of screw yield point.
- · - · - · - Average installation strength for KOBSERT® threaded inserts.

Tools for KOBSERT® Threaded inserts

Manual installation tools S 4 to S 12

Spindle drive

■ **Functional principle:**

Manual screwing-in of thread insert and spindle, drive-in procedure through manual removal with thread spindle drive. Indirect limitation of stroke through manually applied torque.

■ **Application:**

Smaller series. All types of KOBSERT® thread inserts can be installed.

■ **Technical data:**

Capacity up to 4 pieces/min, weight 0.5 – 1.0 kg, max. setting stroke 12 mm, max. setting force approx. 15 kN.



Description Type	Specified Ø	Order no.
S 4	M 4	1053 010 4000
S 5	M 5	1053 010 5000
S 6	M 6	1053 010 6000
S 8	M 8	1053 010 8000
S 10	M 10	1053 011 0000
S 12	M 12	1053 011 2000

Further dimensions and special tools on request.
Subject to technical alterations.

Tools for KOBSERT® Threaded inserts

Manual installation tools HH 830

Hydraulic-manual drive

■ **Functional principle:**

Manual screwing-in of thread insert and spindle, drive-in procedure hydraulic with lifting lever and manual removal. Limited stroke due to stop ring. Change of wear parts by screwing out threaded mandrel and nozzle.

■ **Application:**

Smaller series. All types of KOBSERT® thread inserts can be installed.

■ **Technical data:**

Capacity up to 3 pieces/min, weight 2.0 kg, max. setting stroke 5.0 mm, max. setting force 60 kN, from M14, the threaded mandrel is a two-piece design consisting of threaded mandrel and adapter incl. HELICOIL® screwlock.



Order no. 1050 0500 000

Specified Ø	Tension mandrel comprising threaded mandrel and screw Order no.	Spares Adaptor Order no.	Chuck Order no.	Replacement unit Order no.
M 8	1050 0508 020	–	1050 0508 030	1050 0508 010
M 10	1050 0510 020	–	1050 0510 030	1050 0510 010
M 10 x 1	1050 0510 420	–	1050 0510 030	1050 0510 410
M 12	1050 0512 020	–	1050 0512 030	1050 0512 010
M 12 x 1.5	1050 0512 420	–	1050 0512 030	1050 0512 410
M 14	1050 0514 020	1050 0514 025	1050 0514 030	1050 0514 010
M 14 x 1.5	1050 0514 420	1050 0514 425	1050 0514 030	1050 0514 410
M 16	1050 0516 020	1050 0516 025	1050 0516 030	1050 0516 010
M 16 x 1.5	1050 0516 420	1050 0516 425	1050 0516 030	1050 0516 410
M 18	1050 0518 020	1050 0518 025	1050 0518 030	1050 0518 010
M 18 x 1.5	1050 0518 420	1050 0518 425	1050 0518 030	1050 0518 410
M 20	1050 0520 020	1050 0520 025	1050 0520 030	1050 0520 010
M 22	1050 0522 020	1050 0522 025	1050 0522 030	1050 0522 010
M 22 x 1.5	1050 0522 420	1050 0522 425	1050 0522 030	1050 0522 410
M 24	1050 0524 020	1050 0524 025	1050 0524 030	1050 0524 010
M 24 x 1.5	1050 0524 420	1050 0524 425	1050 0524 030	1050 0524 410
M 26	1050 0526 020	1050 0526 025	1050 0526 030	1050 0526 010
M 26 x 1.5	1050 0526 420	1050 0526 425	1050 0526 030	1050 0526 410
M 30	1050 0530 020	1050 0530 025	1050 0530 030	1050 0530 010
M 30 x 1.5	1050 0530 420	1050 0530 425	1050 0530 030	1050 0530 410

Special tools on request.
Subject to technical alterations.

Mechanical setting tool P 2005 K

Hydraulic-pneumatic drive

■ **Functional principle:**

Spinning on the thread insert with touch automatic at the spindle. Drive-in hydraulic-pneumatic as well as automatic spin-off. Limited stroke due to adjusting collar. Change of threaded mandrel with bayonet lock.

■ **Application:**

Medium series. All types of KOBSERT® thread inserts can be installed.

■ **Technical data:**

Capacity: up to 15 pieces/min, weight: 2.6 kg, maximum setting stroke: 7 mm, setting force: 21 kN at 5.5 -7 bar.

Order no. 1061 550 000



Specified Ø	Complete tool Order no.	Complete replacement unit Order no.	Threaded bolt Order no.
M 4	1061 5504 000	1061 5304 010	2361 1304 020
M 5	1061 5505 000	1061 5305 010	2361 1305 020
M 6	1061 5506 000	1061 5306 010	2361 1306 020
M 8	1061 5508 000	1061 5308 010	2361 1308 020
M 10	1061 5510 000	1061 5310 010	2361 1310 020
M 10 x 1	1061 5510 300	1061 5310 310	2361 1310 320
M 12	1061 5512 000	1061 5312 010	2361 1312 020
M 12 x 1.5	1061 5512 400	1061 5312 410	2361 5312 410

Special tools on request.
Subject to technical alterations.

Tools for KOBSERT® Threaded inserts

Mechanical setting tool PH 830

Hydraulic-pneumatic drive

■ **Delivery scope:**

The installation tool is delivered with power unit E 250 with adjustable drive-in pressure ranging from 100 to 350 bar. Electric hydropump including electric foot pedal switch.

A test assembly must be carried out to check drive-in pressure.

■ **Dimensions:**

M 8 to M 30 x 1.5

■ **Functional principle:**

Spinning on the thread insert through tilting lever actuation, drive-in procedure hydraulic-pneumatic with separate activation or pedal actuation and removal through tilting lever actuation. Limited stroke due to adjusting collar. Change of threaded mandrel with bayonet lock.

■ **Application:**

Large series. All types of KOBSERT® thread inserts can be installed.

■ **Technical data:**

Capacity up to 10 pieces/min, weight 5.0 kg, max. setting stroke 8.0 mm, max. setting force 77 kN, from M 14, a motor with higher performance is used.

Basic tool

Order no. 1061 170 0000

Power unit E 250

Order no. 1065 020 0000

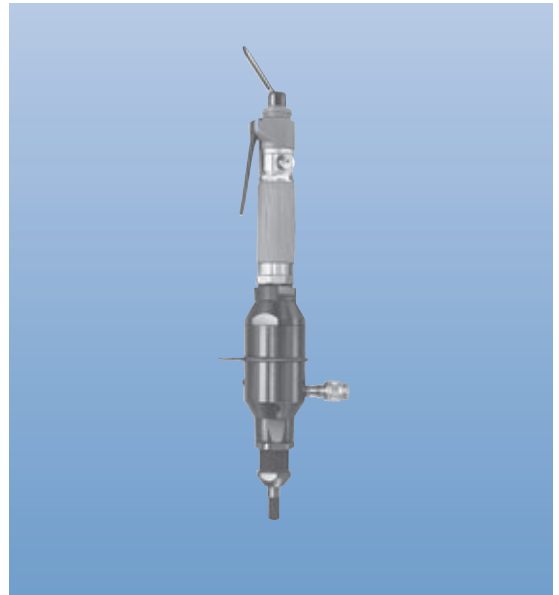

Replacement unit Order no.	Spares	
	Threaded bolt Order no.	Chuck Order no.
1061 17xx y10	1061 17xx y20	1061 17xx y30

xx: Metric specification

y: 0 = standard thread / 4 = fine thread

Example M 12 x 1.5: xx = 12; y = 4

Special threads on request (e.g. buttress threads S 18 x 2)

Tools for rent on request.

Subject to technical alterations.

Böllhoff International with companies in:

Argentina
Austria
Brazil
Canada
China
Czech Republic
France
Germany
Hungary
India
Italy
Japan
Mexico
Poland
Romania
Russia
Slovakia
Spain
Turkey
United Kingdom
USA

Apart from these 21 countries, Böllhoff supports its international customers in other important industrial markets in close partnership with agents and dealers.



Made of paper certified with the Ecolab of the European Community (Reg No. FR/11/003).
Printed by FSC®-certified company GFA-COC-001790.

Subject to technical change.
Reprinting, even in extract form, only permitted with express consent.
Observe protective note according to DIN 34.

OCEANUS

HAI JU TRADING CO.,LTD.

海聚貿易有限公司

台北市中山區中山北路二段62巷36號

TEL : (02) 2511-8900

FAX : (02) 2511-8902

P.C. : 10448

E-MAIL : Hai.ju@msa.hinet.net

HTTP : www.oceanus.com.tw

